

Four-Row Wide Rail

Linear Guideway **WE** Series

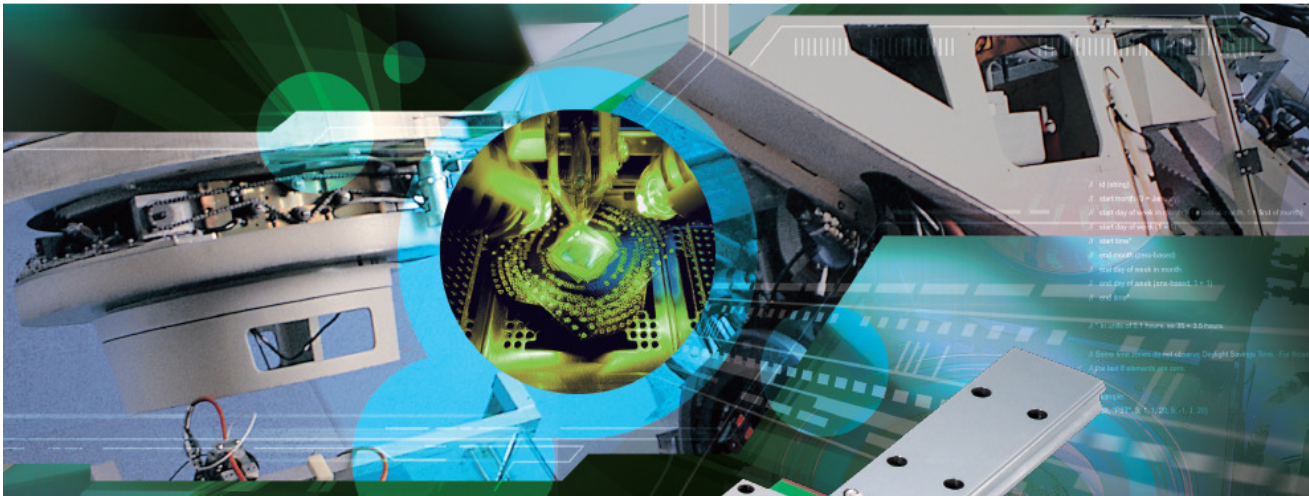

WE Series

The WE series features equal load ratings in the radial, reverse radial and the lateral direction with contact points at 45 degrees. This along with the wide rail, allows the guide way to be rated for high loads, moments and rigidity. By design, it has a self-aligning capability that can absorb most installation errors and can meet high accuracy standards. The ability to use a single rail and having low profile with a low center of gravity is ideal where space is limited and/or high moments are required.

Four-Row Wide Rail

WE Series

Features for WE Series

- High Moment Capability**
 The rail of the WE type linear guideway has two rows of mounting holes increasing the mounting strength of the rail. The width is 1.5 times larger than the traditional size rails. This also increases the moment load capacity of the block.
- Rated Loads in All Directions**
 WE series is capable of receiving loads in four directions: radial, reverse radial, and lateral directions.
- Structure Analysis**

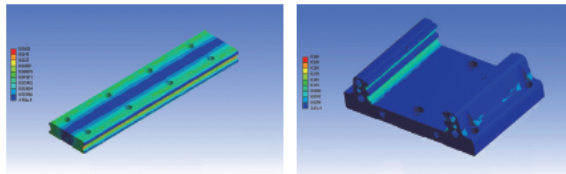
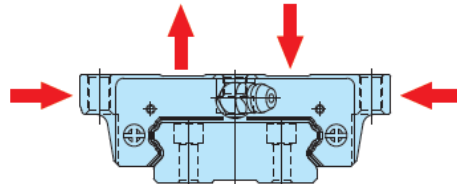
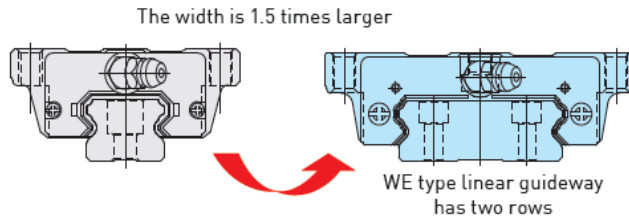

Applications

- ◆ Automations
- ◆ Transportation devices
- ◆ Precision measuring equipments
- ◆ Semi-conductor equipment
- ◆ Blow moulding machine
- ◆ Single Axis Robot- Robotics

WE Block Types

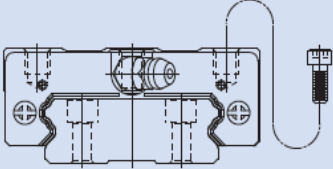
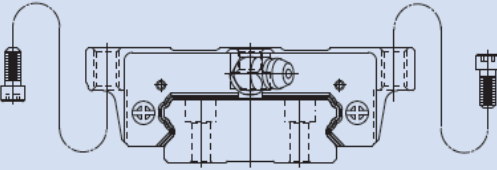
Type	Model	Shape	Height (mm)	Rail Length (mm)
Square	WEH-CA		27 ↓ 35	100 ↓ 4000
Flange	WEW-CC		27 ↓ 35	100 ↓ 4000

Model Number

Example: WEW27CCE2R1600EZA P II + KK

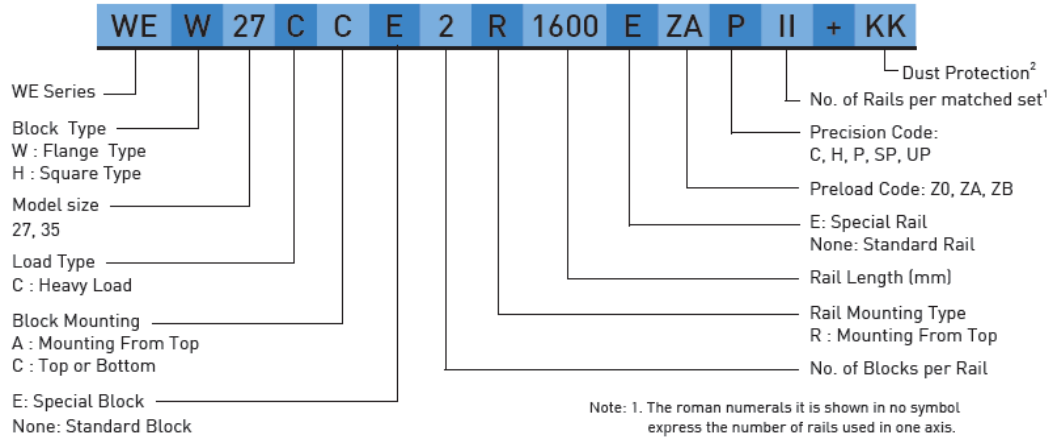

Note: 1. The roman numerals it is shown in no symbol express the number of rails used in one axis. As for the single rail in an axis, it shows no symbol.
 2. For dust protection, it is no symbol if it is standard (end seal and bottom seal).
 ZZ: End seal, bottom seal and scraper.
 KK: Double seals, bottom seal and scraper.
 DD: Double seals and bottom seal.

Preload

Class	Code	Preload
Light preload	Z0	0~ 0.02C
Medium preload	ZA	0.03C~ 0.05C
Heavy preload	ZB	0.06C~ 0.08C

Standard and Maximum Lengths of Rail

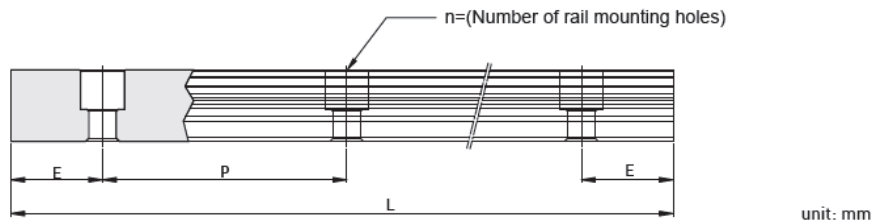

Item	WER27	WER35
Standard Length L(n)	220 (4)	280 (4)
	280 (5)	440 (6)
	340 (6)	600 (8)
	460 (8)	760 (10)
	640 (11)	1000 (13)
	820 (14)	1,640 (21)
	1,000 (17)	2,010 (26)
	1,240 (21)	2,520 (32)
	1,600 (27)	3,000 (38)
Pitch (P)	60	80
Distance to End [E ₁]	60	20
Max. Standard Length	4,000 (67)	3,960 (50)
Max. Length	4,000	4,000

Accuracy Classes

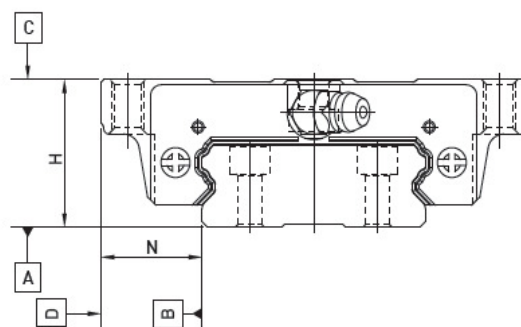

Type	WE27, WE35				
Accuracy Classes	Normal (C)	High (H)	Precision (P)	Super Precision (SP)	Ultra Precision (UP)
Dimensional tolerance of height H	± 0.1	± 0.04	0 - 0.04	0 - 0.02	0 - 0.01
Dimensional tolerance of width N	± 0.1	± 0.04	0 - 0.04	0 - 0.02	0 - 0.01
Variation of height H	0.02	0.015	0.007	0.005	0.003
Variation of width N	0.03	0.015	0.007	0.005	0.003
Running parallelism of block surface C to surface A	See chart below				
Running parallelism of block surface D to surface B	See chart below				

Accuracy of Running Parallelism

Rail Length (mm)	Accuracy (µm)				
	C	H	P	SP	UP
~ 100	12	7	3	2	2
100 ~ 200	14	9	4	2	2
200 ~ 300	15	10	5	3	2
300 ~ 500	17	12	6	3	2
500 ~ 700	20	13	7	4	2
700 ~ 900	22	15	8	5	3
900 ~ 1,100	24	16	9	6	3
1,100 ~ 1,500	26	18	11	7	4
1,500 ~ 1,900	28	20	13	8	4
1,900 ~ 2,500	31	22	15	10	5
2,500 ~ 3,100	33	25	18	11	6
3,100 ~ 3,600	36	27	20	14	7
3,600 ~ 4,000	37	28	21	15	7

Dimensions for WEH-CA

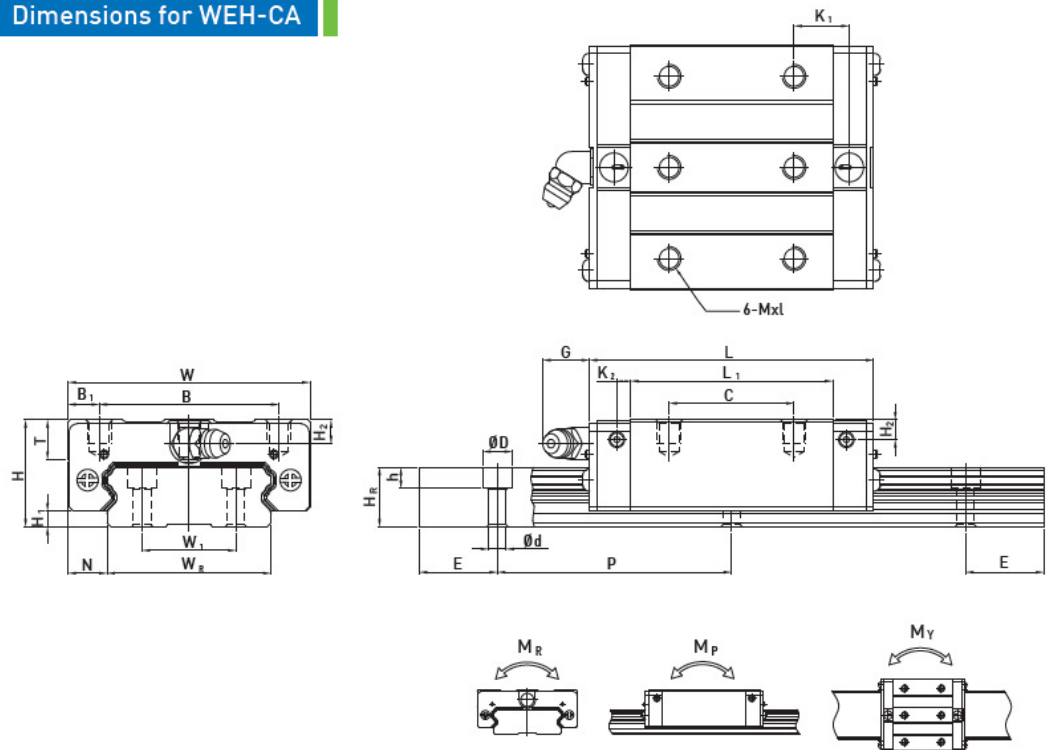

Model No.	Dimensions of Assembly (mm)			Dimensions of Block (mm)											Dimensions of Rai (mm)										Mounting Bolt for Rai (mm)	Basic Dynamic Load Rating C (kN)	Basic Static Load Rating C _s (kN)	Static Rated Moment			Weight	
																												M _x	M _y	M _z	Block	Rail
	H	H ₁	N	W	B	B ₁	C	L ₁	L	K ₁	K ₂	G	MxL	T	H ₂	H ₃	W ₂	H ₄	D	h	d	P	E	kN-m				kN-m	kN-m	kg	kg/m	
WEH27CA	27	4	10	62	46	8	32	51.8	72.8	14.15	3.5	12	M4x6	10	6	5	42	24	15	7.5	5.3	4.5	60	20	M4x16	12.4	21.6	0.47	0.17	0.17	0.35	4.8
WEH35CA	36	4	15.5	100	76	12	50	77.6	104.6	18.1	5.25	12	M8x8	13	8	6.5	69	40	19	11	9	7	80	20	M6x20	29.8	49.4	1.6	0.67	0.67	1.2	9.9

Dimensions for WEW-CC

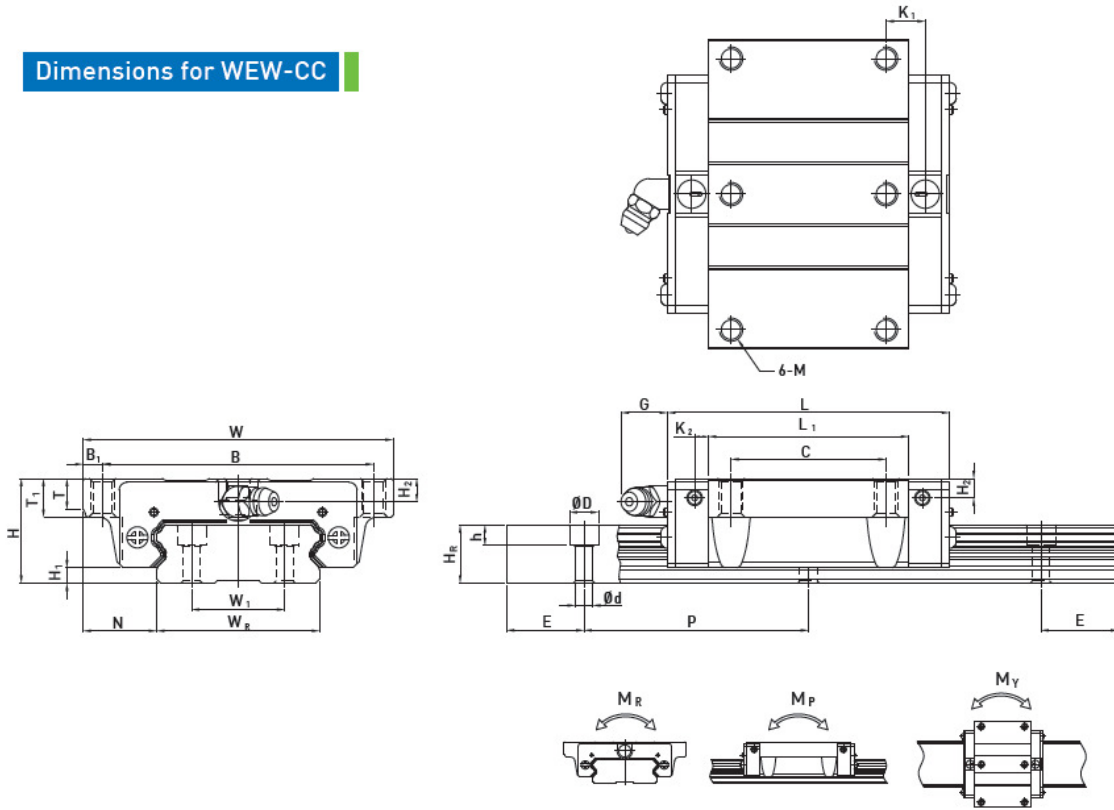

Model No.	Dimensions of Assembly (mm)			Dimensions of Block (mm)										Dimensions of Rail (mm)					Mounting Bolt for Rail (mm)	Basic Dynamic Load Rating C ₁ (kN)	Basic Static Load Rating C ₂ (kN)	Static Rated Moment			Weight							
	H	H ₁	N	W	B	B ₁	C	L ₁	L	K ₁	K ₂	G	MxL	T	T ₁	H ₂	W ₂	W ₃				H ₃	D	h	d	P	E	C (kN)	C ₂ (kN)	M _x (kN-m)	M _y (kN-m)	M _z (kN-m)
WEW27CC	27	4	10	62	46	8	32	51.8	72.8	14.15	3.5	12	M6x6	10	6	5	42	24	15	7.5	5.3	4.5	60	20	M4 x16	12.4	21.6	0.47	0.17	0.17	0.5	4.8
WEW35CC	35	4	25.5	120	107	6.5	60	77.6	104.6	13.1	5.25	12	M8	11.2	14	8	69	40	19	11	9	7	80	20	M6 x20	29.8	49.4	1.6	0.67	0.67	1.35	9.9

The specifications in this catalog are subject to change without notification.



HIWIN TECHNOLOGIES CORP.
 No. 46, 37th Road
 Taichung Industrial Park
 Taichung 40707, TAIWAN
 Tel.: +886-4-23594510
 Fax: +886-4-23594420
 www.hiwin.com.tw
 business@mail.hiwin.com.tw

HIWIN GmbH
 Brücklesbünd 2, D-77654
 Offenburg, GERMANY
 Tel: +49-781-93278-0
 Fax: +49-781-93278-90
 www.hiwin.de
 www.hiwin.eu
 info@hiwin.de

HIWIN SCHWEIZ
 Schachenstrasse 80
 CH-8645 Jona, SWITZERLAND
 Tel: +41-55-2250025
 Fax: +41-55-2250020
 www.hiwin.ch
 info@hiwin.ch

HIWIN JAPAN
 +KOBE
 3F. Sannomiya-Chuo Bldg.
 4-2-20 Goko-Dori, Chuo-Ku
 KOBE 651-0087, JAPAN
 Tel: +81-78-2625413
 Fax: +81-78-2625686
 www.hiwin.co.jp
 info@hiwin.co.jp

HIWIN S.R.O.
 Katanova 34
 CZ 62000 Brno, CZECH REPUBLIC
 Tel: +420-548-528238
 Fax: +420-548-220233
 www.hiwin.cz
 info@hiwin.cz

HIWIN USA
 +CHICAGO
 1400 Madeline Lane
 Etgin, IL 60124, USA
 Tel: +1-847-8272270
 Fax: +1-847-8272291
 www.hiwin.com
 info@hiwin.com
 +SILICON VALLEY
 Tel: +1-510-4380871
 Fax: +1-510-4380873

HIWIN FRANCE
 24 ZI N°1 EST, BP 78, LE BUAT,
 61302 L'AIGLE cedex, FRANCE
 Tel: +33-2-33341115
 www.hiwin.fr